

# Mega Titan -48 UPS Technical Specifications



## Mega Titan -48 UPS



Publication Issue E

## TABLE OF CONTENTS

PREFACE.....	1
TABLE OF CONTENTS .....	2
RELEASES TO THIS TECHNICAL DOCUMENTATION .....	3
PUBLICATION .....	4
USING THIS TECHNICAL PRACTICE .....	4
INSPECTING SHIPMENT .....	4
PRODUCT OVERVIEW.....	5
FEATURES .....	7
STANDARD.....	7
QUARTER TURN LOCKING DOOR LATCHES.....	8
FACEPLATE OPERATION .....	7
PRODUCT SPECIFICATIONS .....	10
INSTALLATION PROCEDURE.....	11
CLEARANCE REQUIREMENTS.....	12
CABINET GROUNDING INFORMATION .....	13
GROUND WIRE.....	13
GROUNDING DIAGRAM AND PROCEDURE .....	14
APPENDIX A.....	16
TECHNICAL SUPPORT .....	18
ORDERING PROCEDURE.....	18
APPENDIX B.....	19
CORPORATE POLICY.....	19
RMA PROCEDURE.....	19
APPENDIX C.....	20
ESPI STANDARD TERMS AND CONDITIONS.....	20

**UL60950-1/CSA C22.2 No. 60950-1, Second Edition: Safety of  
Information Technology Equipment, Rev. March 27, 2007.**

**UL 60950-22 Second Edition: Information Technology Equipment –  
Safety – Part 22: Equipment to be Installed Outdoors,  
Dated March 31, 2017.**

**File: E212519**

## **RELEASES TO THIS TECHNICAL DOCUMENTATION**

---

Issue Level	Date	Description of Revision
A	02/28/2017	Initial Release
B	05/31/2017	Update overall size of cabinet and misc. components
C	06/19/2017	Update Product specifications
D	07/11/2017	Add Safety Specifications

---

Thank you for purchasing the ESPi Mega Titan -48V UPS. We at ESPi are very proud of the quality products we innovate and manufacture. We look forward to serving you as our customer. Please review all sections of this document before the usage of the ESPI product in which this manual pertains.

This document pertains to MT-80A-48, and its family of products.

### Applicable Model Numbers:

MEGA TITAN 48 (MT-80A-150W)

### Contact information

[sales@espicorp.com](mailto:sales@espicorp.com) (sales related questions)

[info@espicorp.com](mailto:info@espicorp.com) (technical support & RMA)

Telephone: 877-799-3774

## **PUBLICATION**

This publication provides a description of the ESPI's models MT-80A-150W UPS. In this publication, an overview of the product, mechanical descriptions, installation instructions, safety guidelines and grounding instructions are included.

## **USING THIS TECHNICAL PRACTICE**

Before using this document, please review the statements below.

1. The differences in models of the Mega Titan family of ESPI products are defined by the attributes within the model number. Definitions of the attributes are described below.
  - MT-XXA-XXXW-
  - MT = Mega Titan Family
  - 80A= 80Ah Battery Size
  - 150W= Max Wattage
2. Two types of messages appear throughout this manual, identified by the following icons:



**Note** - Indicates special conditions.



**Caution** - Indicates possibility of personal injury or equipment damage.

## **INSPECTING SHIPMENT**

On receipt of the equipment:

- Inspect the shipping container(s) and note any signs of damage. Then unpack the container(s) and carefully inspect for damage to the contents. If the equipment has been damaged in transit, immediately report the extent of damage to the transportation company and to ESPI. Order replacement equipment if necessary.
- Check the packing list to assure complete and accurate shipment of all listed items. If the shipment is short or irregular, contact ESPI as described in the Warranty. If the equipment must be stored for a prolonged period, do so in the equipment's original container. If equipment ever needs to be returned, please use the original packaging if available.

## **PRODUCT OVERVIEW**

The Mega Titan is a -48V UPS designed for powering MDU ONT's and other equipment rated up to 150W. The unit contains a lead acid battery and care should be given to prevent housing a UPS system with battery back-up. The cabinet is sized to accommodate (1) UPS and (1) backup battery. The UPS faceplate is internally mounted. A viewport lens is provided on the front door for LED viewing on the faceplate.

The cabinet is constructed of carbon steel and powder coat painted for superior strength and corrosion resistance. The front door is equipped with (1) quarter-turn pad lockable latching system. The cabinet has overall dimensions of 16.25" (412.75 mm) high x 13.38" (339.73 mm) wide x 9" (228.6 mm) deep. See the figures on the following pages for details.

## **SAFETY PRECAUTIONS**

- USE COMMON SENSE!
- Only qualified personnel should service this equipment
- The battery contains hazardous currents and may present a burn hazard if damaged, shorted, or installed improperly.
- The following precautions should be followed to insure your safety
  - Remove watches, rings, or other metallic objects.
  - Wear protective clothing and eye protection when working with batteries
  - Always carry a water supply to wash eyes or skin in the event of exposure to battery electrolyte
  - Use of tools with insulated handles is required
  - Do not disassemble the unit. No user serviceable parts are inside except the battery and fuse
  - Keep liquid and foreign objects from getting inside the unit
  - Avoid operating unit in excessive humidity or near water
  - Do not operate near gas or fire
  - Inspect unit for leaking substance. If substance is leaking, do not use product
  - Servicing this equipment may require working with protective covers removed and utility power connected. Use extreme caution during these procedures.
  - Check that power cord, plugs, and output terminals are in good working order
  - BATTERY WARNINGS – Danger of explosion if battery is incorrectly connected. Use only approved replacement batteries
  - Worn out or damaged batteries are considered environmentally unsafe. ALWAYS recycle used batteries in accordance with all federal, state, and local regulations. This is your planet too!
  - Any gel or liquid emissions from a VRLA battery contain sulfuric acid, which is harmful to the skin and eyes.
  - Batteries can produce explosive gases. Avoid all open flames and sparks.
  - Batteries contain or emit chemicals known to the State of California to cause cancer and birth defects or other reproductive harm. Battery post terminals contain lead and lead compounds. Wash hands after handling. (California Proposition 65)
  - Wear protective clothing and eye protection when installing, maintaining, servicing, or replacing batteries.
  - If battery emissions contact the skin or eyes, immediately wash area with water. Report chemical spills and seek medical attention if necessary.
  - Always replace batteries with new batteries of identical type and rating.
  - A battery showing signs of cracking, leaking, or swelling should be replaced immediately with an approved battery.

## **FEATURES**

### **STANDARD**

- Supports -48V up to 150W
- Battery alarms for Low Battery, Battery Missing, Replace Battery, and On Battery
- 80Ah GS Battery PYL80TT
- Push and hold reset button
- 14' AC Power cord
- Battery Capacity display
- Replaceable AC fuse
- Replaceable battery fuse
- Utility Power Status LED
- Powder Coated Steel enclosure
- Single point latch, padlockable.
- Stainless Steel hardware
- Front door viewport lens.
- Cable entry with strain relief.
- Battery retaining bracket.
- Wall/Pole mounting brackets.

## QUARTER TURN LOCKING DOOR LATCHES

The cabinet door is equipped with a single quarter-turn padlockable latch. The latch is secured by turning the 7/16" hex security bolt one quarter turn clockwise until the stop is reached. A convenient security locking hasp is factory installed to allow for a standard Master lock (or equivalent) to be installed. With a padlock inserted, the security bolt cannot be accessed. Thus, protecting the cabinet from undesired intrusions.

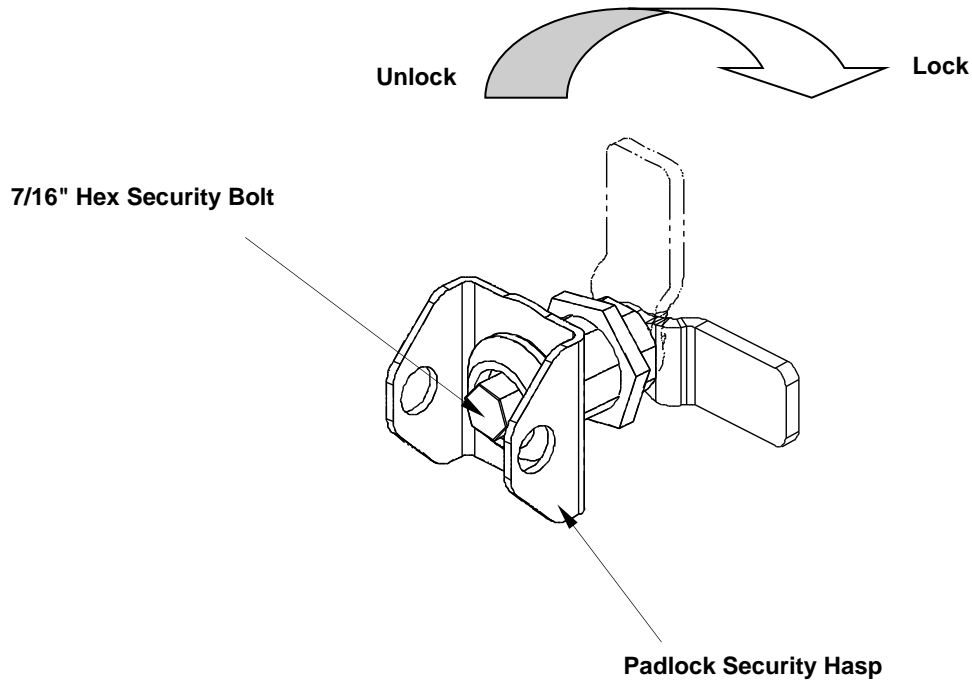

**Figure A – Quarter Turn Locking Door Latch**



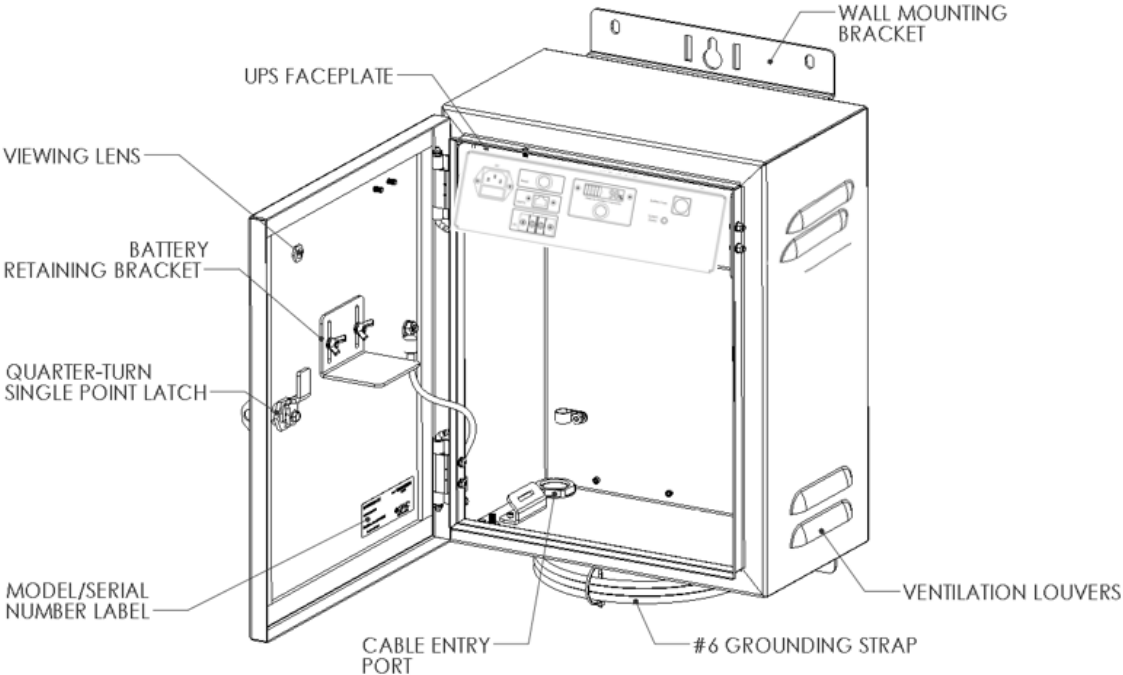

**Figure B – Front View of Cabinet w/ Door Open**

Image is for reference only

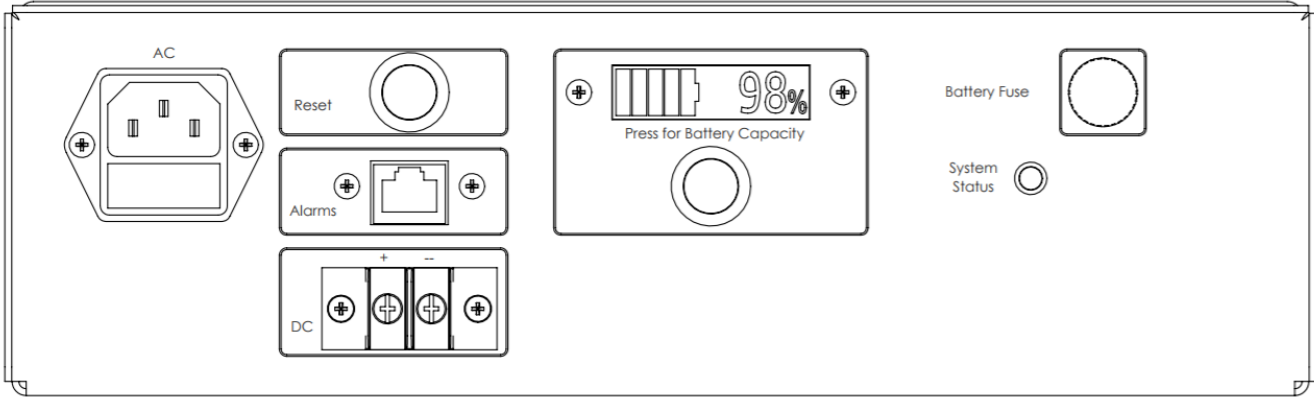
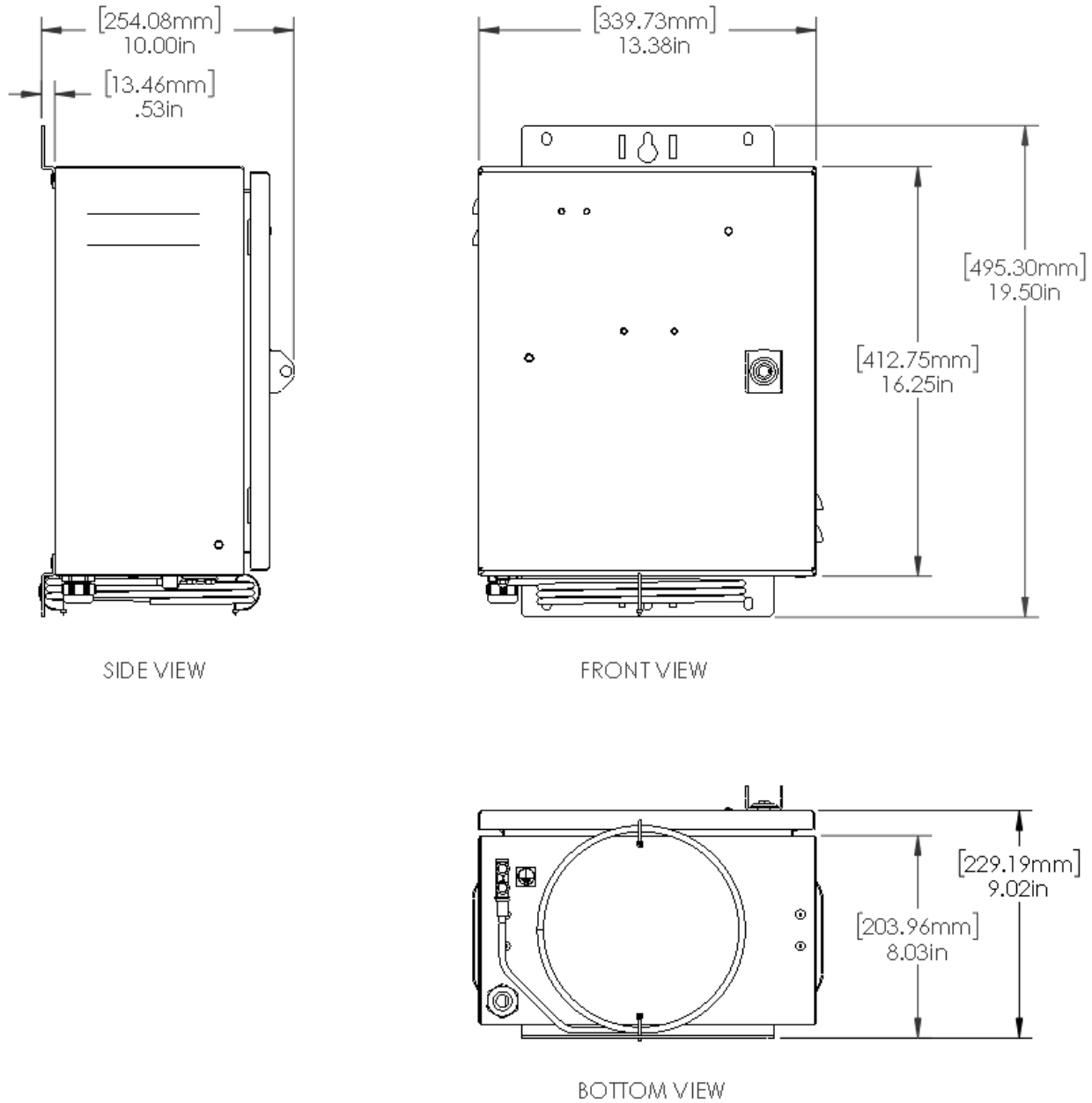

**Figure C – UPS Faceplate**

## **PRODUCT SPECIFICATIONS**

Approximate cabinet outer physical dimensions:

Height	–	16.25" (412.75 mm)
Width	–	13.38" (339.73 mm)
Depth	–	9" (228.6 mm)
Approx. Weight	–	75 lbs. [with battery]



**Figure D – Cabinet Overall Dimensions**

## **INSTALLATION PROCEDURE**

The Installation of the unit must be performed by skilled technicians and electricians familiar with electrical equipment. Do not allow unqualified personnel to handle, install, or operate the equipment. Install this unit in a sheltered location away from gas, fire, and potential sparks. Although the Mega Titan has been designed to survive extreme climates, consider locations that are not in the direct sun to get the maximum battery life. Mega Titan-48 Series cabinet is shipped ready for equipment and battery installation.

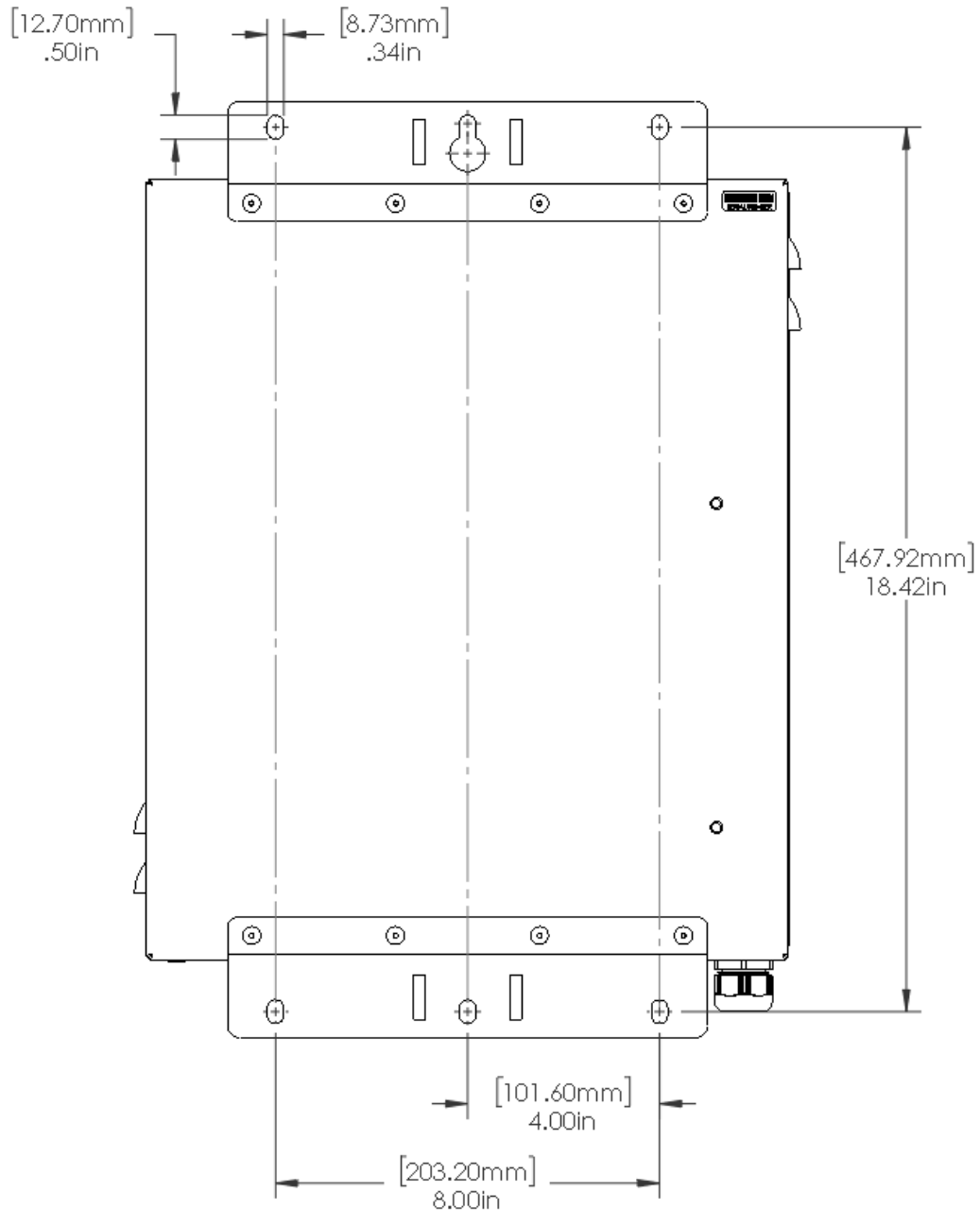

**Figure E – Cabinet Mounting**

## **CLEARANCE REQUIREMENTS**

When selecting a location to mount the cabinet, ensure that proper clearance is available to allow adequate ventilation and to allow the cabinet door to open fully. See figure below for top view of cabinet footprint.

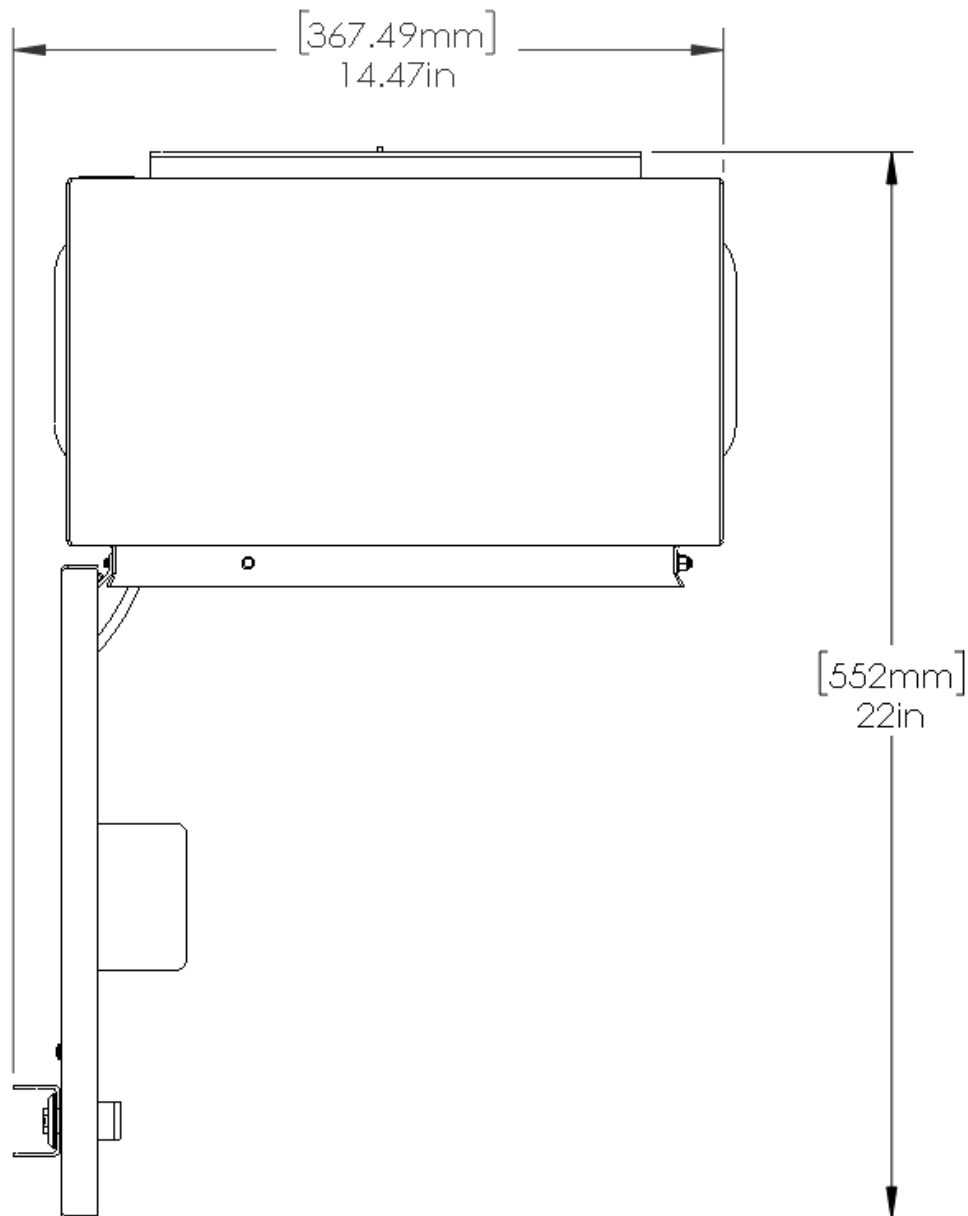

**Figure F – Cabinet Footprint**

## **CABINET GROUNDING INFORMATION**

**Bonding and grounding should be done in accordance with the operating telephone company's standard procedures and comply with local electrical codes.**

### **GROUND WIRE**

The ground wire protects the electronics from voltage surges. A #6 ground wire must be properly grounded to provide lightning surge protection for the cabinet. Please follow this practice for attaching the ground unless local policies dictate otherwise.

**For safety and performance reasons it is imperative that a cabinet be properly grounded. The following guidelines should be used to ground the cabinet unless local practices, rules, or regulations dictate otherwise.**

Each door and equipment rack is grounded to the cabinet frame. The cabinet frame is connected to the internal grounding bus by a stranded wire. A similar ground wire must be used to connect the ground bus to each equipment ground lug. These ground wires may need to be removed temporarily to troubleshoot ground faults. The wire may be removed by unscrewing the screws that secure the green wire to the ground bus. **Be sure to reattach these wires after troubleshooting and resolving any ground conflicts.**

Be sure to ground the cabinet before connecting power to the cabinet. This grounding must be in effect at all times to safeguard personnel.

## GROUNDING DIAGRAM AND PROCEDURE

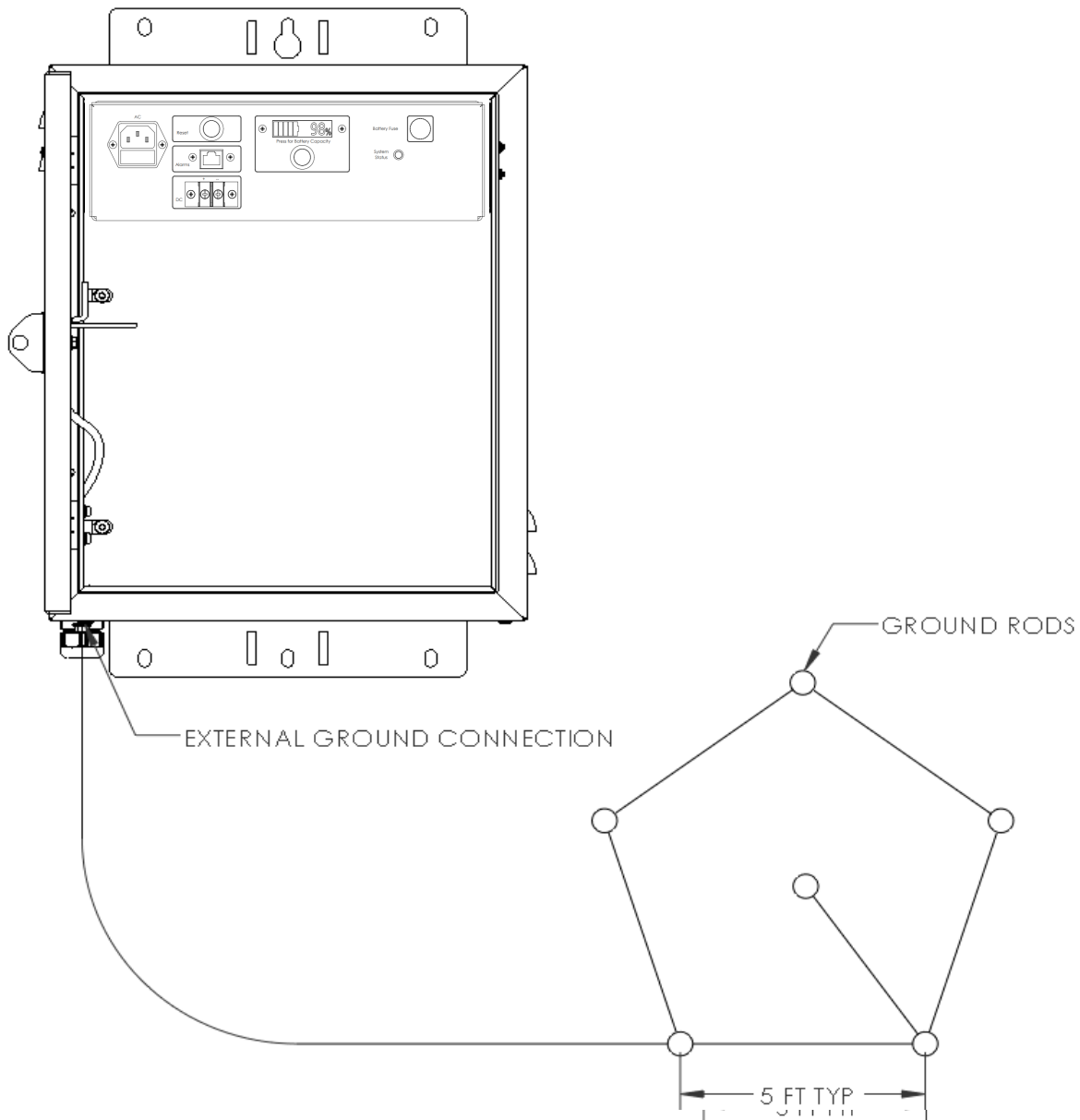
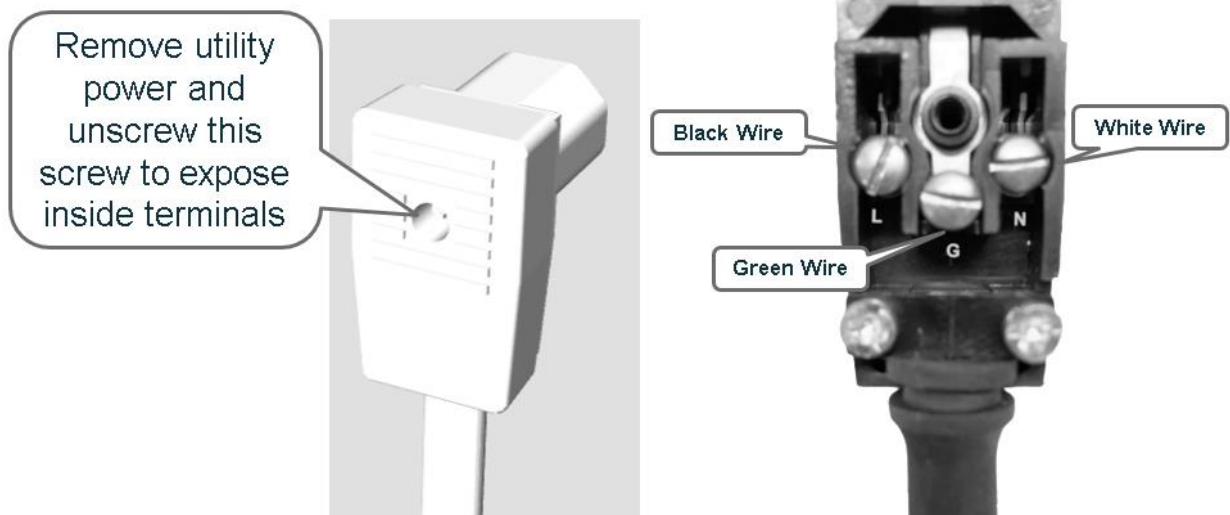

**Figure G – Grounding Diagram**

To ground the cabinet, see above figure.

1. Drive the ground rods into the ground near the cabinet location.
2. Use a Megger-type ohmmeter to measure the resistance between cabinet ground and the ground rods. The resistance must be 25 ohms or less.
3. If the ohm requirement in step 2 is met proceed to step 4. Otherwise, follow local practices to lower the resistance to ground to comply with step 3 before proceeding to step 4.
4. Connect a #6 ground wire to the ground rods.
5. Install the battery inside the enclosure being careful not to short the terminals to any metal object.
6. Connect the alarms to the RJ-45 terminal using the color code in Figure H.
7. Connect the wire from the DC terminal block to your device.
8. Connect the black battery terminal to the negative battery post.
9. Connect the red battery terminal to the positive battery post.

To terminate AC power directly from the utility meter, disassemble the included AC cord and terminate wires as shown below



## Alarm connectors

The alarm connections are placed on an RJ-45 cable for easy termination. Refer to figure H below for the pinout

PIN1 – (White/Green)	On Battery Alarm (battery is providing the power)
PIN2 – (Green)	Ground for On Battery Alarm
PIN3 – (Orange/White)	Battery Missing (Battery is not physically connected)
PIN4 – (Blue)	Low Battery Alarm
PIN5 – (Blue/White)	Ground for Low Battery Alarm
PIN6 – (Orange)	Ground for Battery Missing
PIN7 – (Brown/White)	Replace Battery (Battery is at the end of its useful life)
PIN8 – (Brown)	Ground for replace Battery

Note: Some ONT's have a single return ground for all alarms. In this case, connect all return ground wires for the alarms together. Please consult your ONT manufacture product guide for proper wiring.

### Figure H – Alarm Pinout Diagram

Note for Calix E3-12C users: Set alarms to closed (triggered mode).DB-9 Connection is below.

Alarm	Calix DB-9	MegaTitan-RJ45
AC Fail/On Battery	Brown	White/Green
AC Fail/On Battery (GND)	White/Brown	Green
Battery Missing	Red	White/Orange
Battery Missing (GND)	Red/Blue	Orange
Battery Low	Slate	Blue
Battery Low (GND)	White/Slate	White/Blue

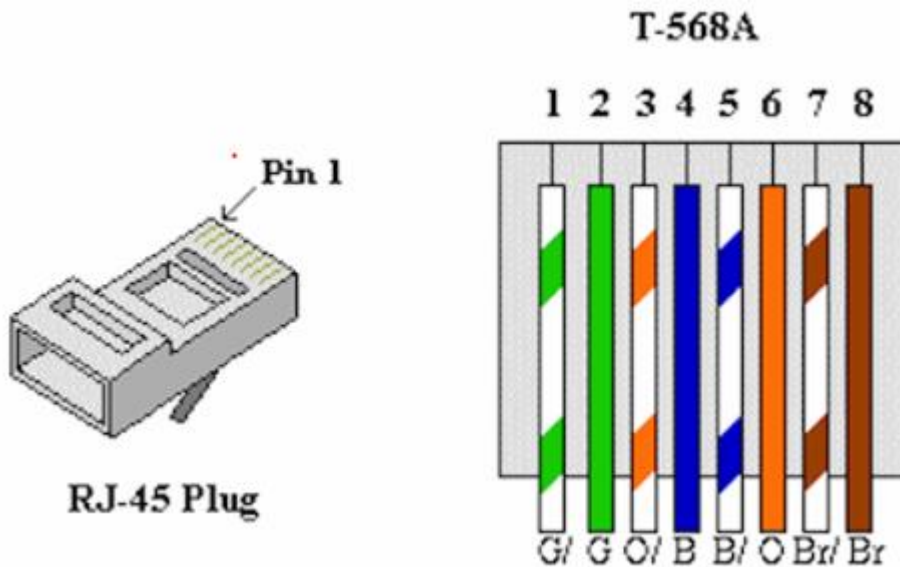



## **Product Operation**

### **Alarms**

The Mega Titan 48 has alarming contacts to alert you of the status of the unit. These alarms are compatible with many dry-contact alarming devices including those included with most telecommunication equipment. The alarms are as follows:

- On Battery – The system does not have incoming power, or the input fuse has blown. Check power outlet and fuse.
- Battery Missing – This alarm means the battery is not present. Check that the battery terminals are properly secured, and the battery voltage is above 5V. Check battery fuse.
- Battery Low – This alarm signifies the battery is at the last 1/3<sup>rd</sup> of its capacity.
- Replace Battery – This alarm signifies the battery is at the end of its useful life and should be replaced. Replace battery with part number PVL-12V-80TT manufactured from GS Battery. Contact ESpI sales for a replacement at 877-799-3774.

### **Reset Button**

The reset button is designed to temporarily remove power to the end device. To activate the reset button, press and hold for 5 seconds to temporarily remove 48v power to the output. Power will automatically be restored after release of the button.

### **AC Inlet Fuse Replacement**

At the bottom of the AC input (IEC Connector) is a fuse. To remove the fuse, slide open the drawer underneath the AC input. Install only a Littlefuse Slow Blow 3A (5mm x 20mm) as a replacement. If this fuse is blown, the UPS will only operate on battery.

### **DC-Output**

The DC output has been designed with your safety in mind. The output is a regulated 48V DC. The output has short circuit protection. Should a short happen, the UPS will recover automatically after the short is removed.

### **Battery Fuse replacement**

Should the battery develop a short, the battery fuse will provide protection. To remove the fuse twist the fuse holder on the faceplate counter-clockwise ½ of a turn. This will release the fuse allowing inspection or replacement. Should the fuse need replacement, replace it only with Littlefuse part number 0313020 (Slow Blow; 20A; Sz 3AG)

### **Battery diagnostics**

The MegaTitan 48 has advanced battery diagnostics allowing accurate detection of a bad battery. Every 45 days a 5-minute battery test occurs. If the battery falls below 25% of its rated 80Ah charge capacity or the battery voltage dips below 11.00V during the test; the battery failure alarm is asserted. When in a failed condition, a follow up retest is scheduled daily until the alarm clears. When a battery is replaced or the unit is started up for the first time the alarm is cleared. The first battery test will be scheduled after 1-day of run time and then every 45 days thereafter.

### **Battery capacity meter**

The battery capacity meter is designed to give you an indication of battery capacity only during discharge. To activate the battery capacity meter, press and hold the button located underneath the display. Keep in mind that the battery will show 100% capacity if the battery is charging after being depleted. This is normal behavior. It will show between 90% and 100% when the battery is completely charged based upon the temperature of the battery.

### **System Status LED**

The system status LED will light up green when utility power is present and 48V is being produced.

## **APPENDIX A**

### **TECHNICAL SUPPORT**

Technical assistance is available 8 AM to 5 PM Central Time.  
Contact ESPI at:

Telephone      877-799-3774 (toll free)

### **ORDERING PROCEDURE**

You may place orders by telephone or email:

Telephone:      877-799-3774 (Toll Free)  
Email:            sales@espicorp.com  
Mail:              ESPI  
                      630 Lincoln St  
                      Clay Center, Kansas 67432

When placing an order, please provide the following information:

- Customer purchase order number
- Ship-to and bill-to addresses
- Part numbers and quantities required
- Requested delivery date
- Preferred method of shipment

## **APPENDIX B**

### **RETURN FOR REPAIR POLICY AND PROCEDURE**

#### **CORPORATE POLICY**

ESPI warrants this product to be free of defects and to be fully functional for a warranty period beginning from the date of original shipment, given correct customer installation and regular maintenance. ESPI will repair or replace any unit without cost during its warranty period if the unit is found to be defective for any other reason other than abuse or incorrect use or incorrect installation.



**Do not try to repair the unit. If it fails, replace it with another unit and return the faulty unit to ESPI for repair. Any modification of the unit by anyone other than an authorized ESPI representative voids the warranty.**

#### **RMA PROCEDURE**

If a unit needs repair, call ESPI at 877-799-3774 (toll free) for an RMA Number and return the defective unit, freight prepaid to:

ESPI  
Shipping & Receiving  
630 Lincoln  
Clay Center, KS 67432  
Attn: Repair Dept.

When preparing the unit for shipment:

- Use the original packaging
- Provide the following information (required):
  - The RMA Number posted on outside of shipping container



**(ESPI will not accept return shipments without an RMA)**

- A statement inside the shipping container with the following details:
  - The RMA Number
  - Description and quantities of equipment being returned
  - Brief description of the problem
  - Your billing address
  - Your shipping address

You will be notified of the reparability of your returned equipment within 2 weeks of receipt of your shipment at the address above.

ESPI will provide needed equipment repair beyond the warranty period for a nominal charge. Contact your ESPI sales representative for details and pricing.

## **APPENDIX C**

### **ESPI STANDARD TERMS AND CONDITIONS**

**ALL QUOTATIONS AND SALES ARE SUBJECT TO THE FOLLOWING TERMS AND CONDITIONS AS WELL AS THOSE CONTAINED ON THE ORIGINAL QUOTATION.**

Warranty: ESPI LLC is very proud of the product we have created. Should you need support please call 877-799-3774 or visit our website at [espicorp.com](http://espicorp.com).

ESPI LLC warrants to you, the Initial Purchaser, that the Product will be free from defects in material and workmanship for three years from the date of original purchase, subject to the terms of this Limited Warranty. This Limited Warranty gives you specific rights, and you may have other rights, which vary from State to State or Province to Province Any Implied Warranty of Merchantability or for Fitness for a Particular Purpose, if applicable to the Product, is limited in duration to three years. This provision shall NOT create any Implied Warranty or Merchantability or of Fitness for a Particular Purpose that would not otherwise apply to the Product. NOTE: Some States and provinces do not allow limitations on how long an implied warranty lasts, so the above limitation may not apply to you.

To be covered you must still be the owner of the Product at the time of the failure that results in the claim made under this Limited Warranty. Your sole and exclusive remedies are those provided by this Limited Warranty. This exclusion of other express warranties applies to written and oral express warranties. ESPI excludes any liability for personal injury. ESPI excludes any liability for direct, indirect, special, incidental, or consequential damages, whether for damage to or loss of property, loss of profits, business interruption, information or data. This exclusion applies even though damage or loss is caused by negligence or other fault. NOTE: Some States or Provinces do not allow the exclusion or limitation of incidental or consequential damages, so the above limitation may not apply to you.

**DO NOT USE FOR MEDICAL OR LIFE SUPPORT EQUIPMENT OR OTHER HIGH RISK ACTIVITIES.**

ESPI does not sell the PRODUCT for use in high-risk activities. The PRODUCT is not designed or intended for use in hazardous environments requiring fail-safe performance, including the operation of nuclear facilities, aircraft navigation or communication systems, air traffic control, weapons systems, life support or medical applications or for use in any circumstance in which the failure of the PRODUCT could lead directly to death, personal injury, or severe physical or property damage, or that would affect operation or safety of any medical or life support device (collectively, "High Risk Activities").

ESPI LLC expressly disclaims any express or implied warranty of fitness for High Risk Activities. ESPI LLC does not authorize use of any of our products in any High Risk activities.

**ANY SUCH USE IS IMPROPER AND IS A MISUSE OF An ESPI PRODUCT.**

The Limited Warranty is governed by the laws of the United States and the State of Kansas, without reference to conflict of law principles. The application of the United Nations Convention of Contracts for the International Sale of Goods is expressly excluded



**ESPI**  
630 Lincoln  
Clay Center, Kansas 67432  
**Toll-Free (877) 799-3774**  
**[www.espicorp.com](http://www.espicorp.com)**

**© August 2021**